

DR90

90 DEGREE DISPLACEMENT DIFFUSER



DR90

90 Degree Displacement Diffuser

The 90 Degree Displacement Diffuser (DR90) supplies low velocity air in a 90° radial pattern directly into the occupied zone. Ceiling/duct or floor mounting options are available. An optional base or duct cover may also be supplied with the unit. These appealing diffusers mesh seamlessly into any décor and as a result may be suitable for schools, office spaces, hotels, and convention centers.



DR90 corner unit

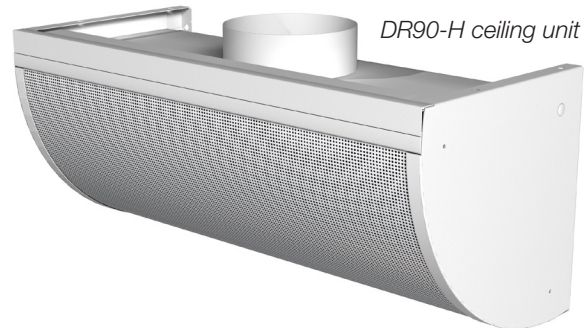

DR90-H ceiling unit

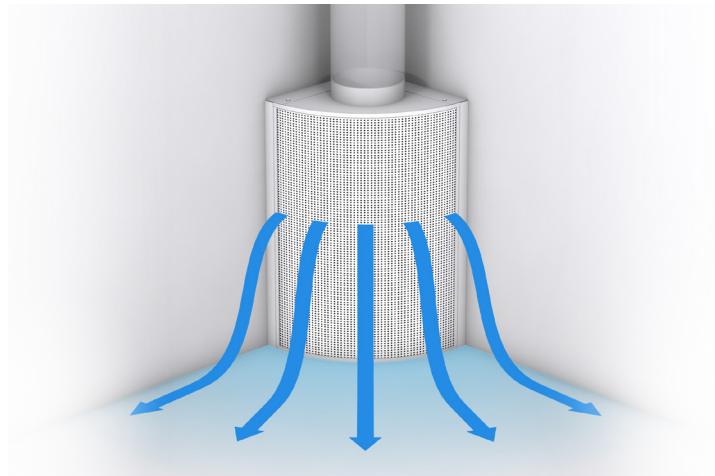

CONSTRUCTION

+ Material

- Frame and equalization baffle – Aluminum
- Plenum and perforated discharge – Steel

+ Mounting

- 90 Corner wall mount (DR90)
- 90 Ceiling mount (DR90-H)

+ Options

- Inlet locations: bottom, top rear, or side

- Field-cut inlet

- Ships with protective film on face and inlet
- Standard finishes: Pure white (B11), White (B12), Aluminum (B15), Black (B17)
- Custom color to match

ACCESSORIES

Duct Cover

Duct covers match the aesthetic of the diffuser while concealing the duct work for an architecturally appealing installation. Duct covers can be supplied in solid steel or perforated material to match the diffuser face. When using a perforated duct cover, the ductwork can be painted black to conceal the ductwork. The duct cover is available in varying lengths and can be split into multiple sections to create a symmetric look with the diffuser. These units are perfect for top ducted diffusers where exposed ductwork is not desired, such as hotel lobbies, office boardrooms, schools, and restaurants. See specific product for availability.

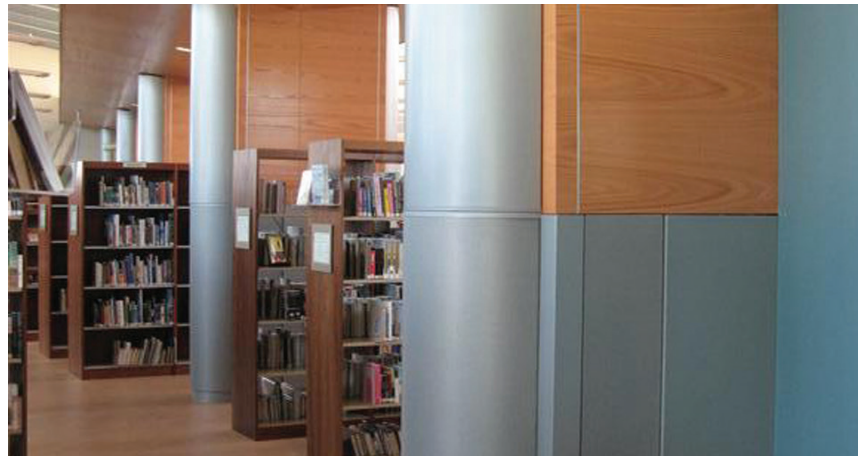

Diffuser cover application

Base Options

The diffuser base can offer a look that is consistent with the rest of the space while concealing the ductwork. The base also provides protection from damage or infiltration of moisture during cleaning. The base is available in varying lengths and is inset from the face of the diffuser by 1 inch. The easy installation of the product allows it to be ordered with a displacement unit or as a secondary order if the look is required after the original diffuser's installation. See specific product for availability.



Diffuser base application

DR90

90 Degree Displacement Diffuser

DIMENSIONAL DATA

DR90 Corner Unit

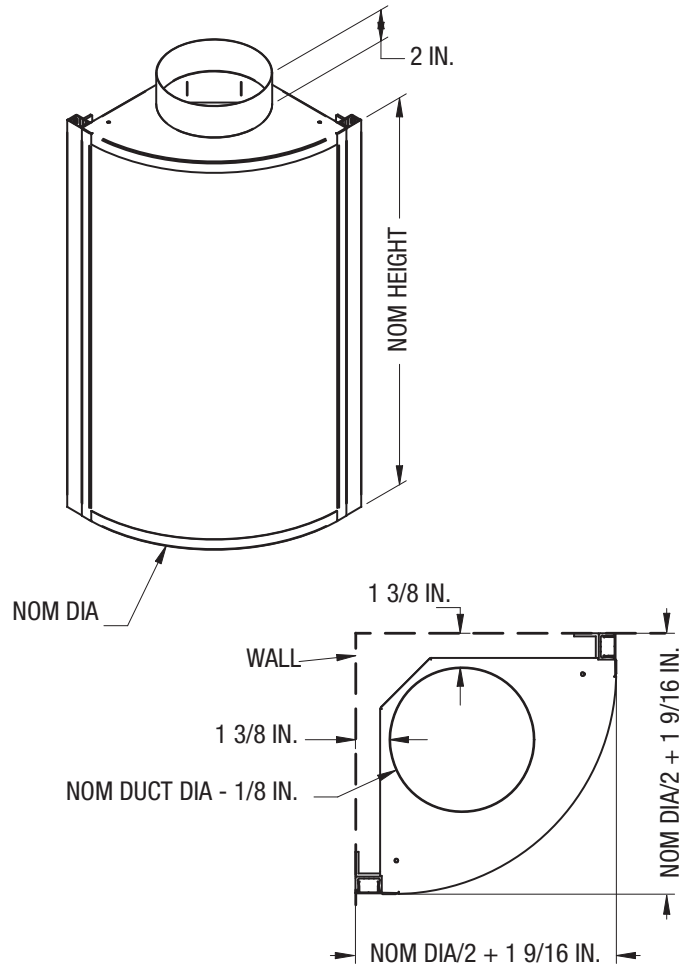

Nominal Size (in.)		DUCT DIA
DIA x H		
18 X 24		4
18 X 36		4
18 X 48		4
24 X 24		6
24 X 24		7
24 X 36		6
24 X 36		7
24 X 48		6
24 X 48		7
24 X 60		6
24 X 60		7
30 X 24		8
30 X 36		8
30 X 48		8
30 X 60		8

Nominal Size (in.)		DUCT DIA
DIA x H		
36 X 24		10
36 X 24		12
36 X 36		10
36 X 36		12
36 X 48		10
36 X 48		12
36 X 60		10
36 X 60		12
42 X 36		12
42 X 48		12
42 X 60		12
48 X 36		14
48 X 48		14
48 X 60		14

Note: Inlets may be located on top or bottom of the diffuser

DR90

90 Degree Displacement Diffuser

DIMENSIONAL DATA

DR90-H Ceiling Unit

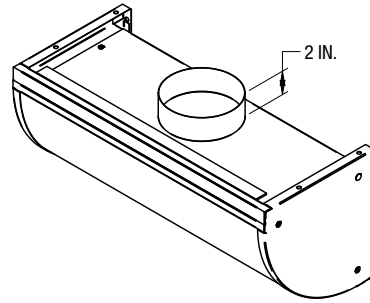
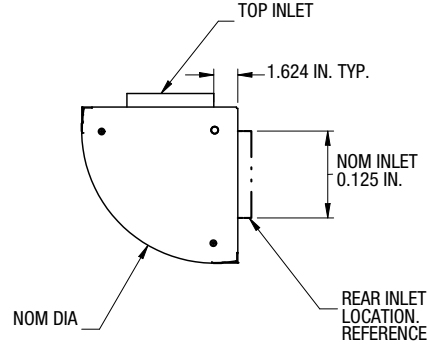
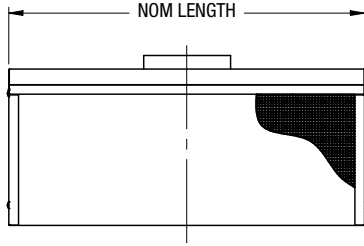

Nominal Size (in.)		
DIA. X LENGTH	NOM DEPTH/ HEIGHT	INLET LOCATION (ROUND)
18 X 24	10 9/16	4, 6
18 X 36		
18 X 48		
18 X 60		
18 X 72		6
18 X 84		
18 X 96		
24 X 24	13 9/16	6, 8, 9
24 X 36		
24 X 48		
24 X 60		
24 X 72		
24 X 84		
24 X 96		
30 X 24	16 9/16	8, 10
30 X 36		
30 X 48		
30 X 60		
30 X 72		
30 X 84		
30 X 96		
36 X 24	19 9/16	10, 12, 14
36 X 36		
36 X 48		
36 X 60		
36 X 72		
36 X 84		
36 X 96		

Nominal Size (in.)		
DIA. X LENGTH	NOM DEPTH/ HEIGHT	INLET LOCATION (RECTANGULAR)
18 X 24	10 9/16	14 X 6
18 X 36		
18 X 48		
18 X 60		
18 X 72		
18 X 84		
18 X 96		
24 X 24	13 9/16	16 X 5
24 X 36		16 X 8
24 X 48		
24 X 60		24 X 8
24 X 72		
24 X 84		
24 X 96		
30 X 24	16 9/16	16 X 8
30 X 36		24 X 8
30 X 48		
30 X 60		24 X 10
30 X 72		
30 X 84		
30 X 96		
36 X 24	19 9/16	18 X 8
36 X 36		24 X 8
36 X 48		
36 X 60		24 X 10
36 X 72		
36 X 84		
36 X 96		

Note: Rectangular inlets may be located on the top or bottom of the diffuser. Round inlets may be located on the left or right end of the diffuser.

DR90

90 Degree Displacement Diffuser

PERFORMANCE DATA

Unit Size Dia. x H [in]	Inlet Size [in]	Face Velocity [fpm]	Air Flow [cfm]	Total Pressure [in. w.g.]	Static Pressure [in. w.g.]	Noise Criteria [NC]	Proximity to Outlet [ft]			
							DR 20%		Adjacent Zone	
							$\Delta T = 5^\circ F$	$\Delta T = 10^\circ F$	$\Delta T = 5^\circ F$	$\Delta T = 10^\circ F$
18 x 24	4	20	41	0.03	0.01	-	-	2	-	1
		30	61	0.06	0.03	-	1	2	1	2
		40	81	0.10	0.05	19	1	3	2	3
		50	102	0.16	0.08	26	1	4	2	4
24 x 24	6	20	56	0.01	-	-	-	1	-	1
		30	83	0.03	0.02	-	1	2	1	2
		40	111	0.06	0.04	-	2	3	2	3
		50	139	0.09	0.06	17	2	4	3	4
30 x 24	8	20	70	0.01	-	-	-	1	-	1
		30	106	0.02	0.02	-	1	3	1	2
		40	141	0.04	0.03	-	2	4	2	4
		50	176	0.06	0.04	-	2	5	3	5
18 x 36	4	20	62	0.03	-	-	-	2	1	2
		30	93	0.06	-	16	1	3	2	3
		40	124	0.11	-	25	2	4	3	5
		50	155	0.18	-	33	2	6	4	6
24 x 36	6	20	85	0.02	0.01	-	1	2	1	2
		30	127	0.05	0.02	-	2	3	2	4
		40	170	0.09	0.04	16	2	5	3	5
		50	212	0.14	0.07	23	3	7	4	7
30 x 36	8	20	108	0.02	-	-	1	2	1	2
		30	162	0.04	0.02	-	2	4	2	4
		40	215	0.06	0.04	-	3	6	4	6
		50	269	0.10	0.06	17	4	8	5	8
24 x 48	6	20	114	0.03	-	-	1	3	2	3
		30	171	0.06	0.01	-	2	5	3	5
		40	229	0.10	0.02	20	3	7	5	8
		50	286	0.16	0.03	28	4	10	6	11
30 x 48	8	20	145	0.02	0.01	-	1	3	2	3
		30	217	0.05	0.02	-	2	6	4	6
		40	290	0.08	0.04	-	4	8	5	9
		50	362	0.13	0.06	21	5	11	7	12
24 x 60	6	20	144	0.02	-	-	2	3	2	4
		30	215	0.05	-	-	3	6	4	7
		40	287	0.09	-	24	4	9	6	10
		50	359	0.15	-	31	6	12	8	14
30 x 60	8	20	182	0.02	-	-	2	4	3	4
		30	273	0.05	0.02	-	3	7	5	7
		40	364	0.09	0.03	17	5	10	7	11
		50	455	0.15	0.04	24	7	14	9	16

Performance Notes:

- Sound and pressure drop tested in accordance with ASHRAE Standard 70-2006 "Method of Testing for Rating the Performance of Air Outlets and Inlets."
- Air flow is in cubic feet per minute, cfm.
- Pressure is in inches of water, in. w.g.
- The NC values, sound pressure level, are based on a room absorption of 10 dB, re 10^{-12} watts and one diffuser.
- ΔT is the difference between the room air temperature 3½ ft above the floor and the temperature of the supply air.
- Proximity to outlet is the minimum distance from an outlet to the occupant in order to achieve the listed DR value.
- Distances closer to the diffuser have a higher DR than the cataloged value.
- DR is the predicted percentage of people dissatisfied (PPD) due to draft. A value of less than 20 meets the requirements of ASHRAE Standard 55-2004, Thermal Environmental Conditions for Human Occupancy.
- Blanks "-" indicate that the DR is below the specified value at all distances from the diffuser face.
- DR catalog data is presented for an occupant density of 25 people/1000ft², which is the default occupancy density for classrooms (ages 5-8) given by ASHRAE 62.1-2004. For other occupant densities, please refer to the DV Room Designer Software.
- The Adjacent zone describes the distance from the face of the diffuser and measured 1 in. from the floor, at which the supply air velocity is 50 fpm.



Product Improvement is a continuing endeavour at Price. Therefore, specifications are subject to change without notice. Consult your Price Sales Representative for current specifications or more detailed information. Not all products may be available in all geographic areas. All goods described in this document are warranted as described in the Limited Warranty shown at priceindustries.com. The complete Price product catalog can be viewed online at priceindustries.com.